



Predictable, continuous and efficient power systems engineered for organizations with zero tolerance for downtime.



250kVA - 1000kVA **CLEANSOURCE® UPS**

battery-free energy storage

high reliability

98% Efficiency

120 150

250 - 1000

kVA

380/400/415

V

SYSTEM FEATURES

- Rugged, on-line and fault-tolerant UPS
- Most efficient UPS architecture
- Handles multi-load characteristics
- Cost-effective lifecycle cost
- Modular and redundant architecture
- Predictable flywheel energy storage
- 20-year design life
- Low service and maintenance requirements
- Smallest available footprint
- Rapid recharge time
- Predictive failure analysis
- Wide operating temperature range
- Remote and local monitoring
- Fault compartmentalisation
- Simple and cost-effective installation
- Multi-vendor generator and switchgear compatibility
- Field-proven reliability
- No hazardous waste material

PARALLEL ONLINE ARCHITECTURE

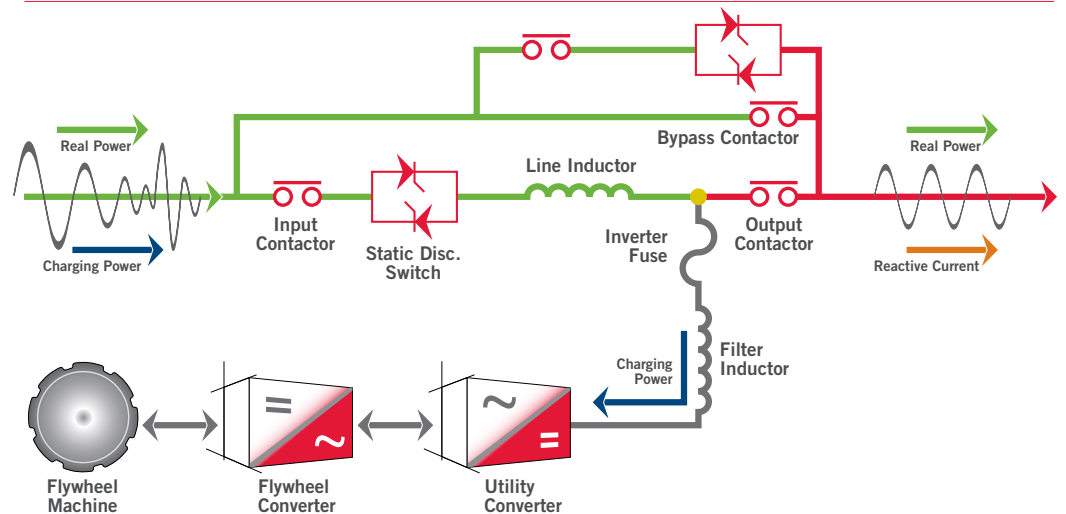

intelligently
EFFICIENT

inherently
RELIABLE

economically
GREEN

CLEANSOURCE UPS **250kVA - 1000kVA**



STANDARD RIDE-THROUGH TIMES (SECONDS)

Load%	Time
100%	15
75%	20
50%	30
25%	56

FACTORY INSTALLED EQUIPMENT

Standard

- IGBT-based UPS technology
- Flywheel energy storage
- Superior power conditioning
- High-speed voltage regulation
- High overload capacity
- Static bypass circuit
- User-friendly color LCD monitor/control panel
- Redundant cooling fans
- Redundant control power
- Power factor correction
- Intelligent self-diagnostics
- Serial connections
- Back-feed protection
- Harmonic cancellation

Optional

- Remote SNMP/MODBUS monitoring capability
- CSView™ – advanced real-time monitoring
- Remote status panel
- Seismic provisions
- Separate bypass input
- Redundant flywheel and UPS
- Upgrade capability from 250 to 1000kVA
- External synchronization input
- GenSTART™ Generator Start Power

PRODUCT SPECIFICATIONS

MODEL	UPS 250i ¹	UPS 250iE	UPS 500i	UPS 750i	UPS 1000iX
RATING					
Maximum kVA	250	250	500	750	1,000
Maximum kW	225	225	450	675	900
INPUT					
Voltage	380/400/415 VAC 3-phase, 4-wire plus ground (from grounded wye source)				
Voltage Range	+10% / -15% (programmable) +/- 10% at 380 VAC				
Frequency ²	50 Hz +/- 10% maximum (programmable) +/- 3% (default)				
Power Factor	0.99 at rated load and nominal voltage				
Harmonic Current Distortion					
Linear Load	<3% at 100% load				
Non-Linear Load ³	<8% at 100% load				
Current - Nominal (380 VAC)	355	355	709	1,064	1,419
Current - Nominal (400 VAC)	337	337	674	1,011	1,348
Current - Nominal (415 VAC)	325	325	650	974	1,299
Current - Max. Continuous	400	400	800	1,200	1,600
Current - Max. Non-Continuous	440	440	880	1,320	1,760
Surge Withstand	Meets IEEE 587/ANSI C62.41				
Walk-In	1 to 15 seconds (programmable)				
OUTPUT					
Voltage	380/400/415 VAC 3-phase, 4-wire plus ground				
Voltage regulation					
Steady state	+/-1% for +/-10% input				
Flywheel mode	+/-1% steady state				
Transient	+/-1% within 50 mSec for 100% load step				
Voltage distortion³					
	<3% linear loads and <5% for 100% non-linear loads				
Frequency ²	50Hz (mains synchronised) (normal operation +/- 0.2% free running)				
Slew Rate	Adjustable from 0.2kHz/second to 3.0kHz/second				
Current - Nominal (380 VAC)	380	380	761	1,141	1,521
Current - Nominal (400 VAC)	361	361	723	1,084	1,445
Current - Nominal (415 VAC)	348	348	696	1,045	1,393
Overload Capability-Mains Operation					
10Ms /1s /30s /10Min Continuous	1000% / 500% / 200% / 125% / Up to 105%				
UPS Efficiency	98%				
Environmental					
Audible Noise		<70 dBA at 1m	<72 dBA at 1m	<75 dBA at 1m	
Temperature					
Operating		0 to 40° C			
Storage		-25 to 70° C			
Humidity					
5% to 95% (non-condensing)					
Altitude					
Up to 1,000 meter (derate operating temperature for higher elevations)					
Emissions and Immunity					
EN 50091-2					
Heat Rejection					
kW	5.8	5.8	11.7	17.5	23.4
BTU/Hr	19,946	19,946	39,893	59,839	79,786
PHYSICAL DATA					
Height (w/o wireway or DC bus)	1,981 mm	1,981 mm	1,981 mm	1,981 mm	1,981 mm
Width	1,641 mm	3,226 mm	4,318 mm	5,410 mm	7,295 mm
Depth	865 mm	865 mm	865 mm	865 mm	865 mm
Weight	2,500 kg	3,494 kg	5,915 kg	8,020 kg	10,544 kg
Cable Entry	Top or Bottom				
Safety	EN60400-1-1				

¹ Not Expandable

² 60Hz Available

³ EN59001-3

World Headquarters

2128 W. Braker Lane, BK12 • Austin, Texas 78758-4028
Tel: 877.BUY.ACPW • Fax: 512.836.4511
sales@activepower.com

European Headquarters

Kensington House • 33 Imperial Square
Cheltenham, Gloucestershire, GL50 1QZ • United Kingdom
Tel: +44 1242 227 188 • Fax: +44 1242 227 765
emea@activepower.com

www.activepower.com

